



VENTIS 206A

Processed Active Speaker

APPLICATIONS

- Band P.A.
- Personal monitor
- Small theatres
- Auditoriums
- Piano bar
- DJ
- Stage monitor
- Conference rooms
- Fixed installations in live clubs
- Pubs
- Gyms

KEY FEATURES

- 2-way bi-amplified bass reflex design
- Biamped: 700W RMS/LF and 200W RMS/HF
- DSP with graphic display
- 0,47" birch plywood scratch resistant enclosure
- High efficiency switch mode power supply
- Control panel features balanced XLR/Jack input, XLR link out, 2 x volume, RCA stereo input, DSP with rotative encoder and push



PRODUCT DESCRIPTION

The FBT VENTIS 206A has been designed to meet the highest standards in both performance and aesthetic appeal. The FBT VENTIS 206A can be deployed as a front fill, an under-balcony fill, as a main providing pristine speech intelligibility or simply as the full-range companion of a subwoofer. The FBT VENTIS 206A incorporating 2 x 6.5" LF woofers with 1.5" voice coil, custom made for FBT and 1" exit throat B&C HF compression driver with 1.4" voice coil; a fully rotatable constant directivity horn ensure accurate coverage (70° H x 50° V). With a frequency range from 70Hz to 20kHz the FBT VENTIS 206A speaker provide high fidelity sound for both speech and music applications with a maximum SPL of 131dB. Low frequencies are driven by a highly efficient 700W RMS (full bridge) Class D topology, operating with extremely low THD; for the HF stage, a 200 W RMS performance is delivered via a meticulously crafted Class H/AB design. DSP on-board is both user friendly and powerful; a total of 6 pre-optimised settings are available, plus 2 further slots for users to form their own designs, using 5 parametric equalizers per slot. Constructed in 0,47" birch plywood, the FBT VENTIS 206A has an integrated rear handle. The optional mounting bracket allow the FBT VENTIS 206A speaker to be surface mounted on walls or ceilings.

ELECTRONIC SPECIFICATIONS

System Type	2 Way
Internal amplifiers LF/HF*	max. 700W / 200W RMS max. peak 1400W / 400W
Input Impedance	22 kOhm
Frequency Response	70Hz - 20kHz (@-6dB)
Maximum SPL cont/peak**	124/131dB
Dispersion	70° H x 50°V rotatable
AC Power Requirement	600VA

PHYSICAL SPECIFICATIONS

Low Frequency Woofer	2 x 6.5" / 1.5" coil
High Frequency Driver	1" / 1,4" coil
Input Connectors	XLR with loop / RCA st.
Net Dimensions (WxHxD) inch	7.48 x 21.45 x 10.23
	mm
	190 x 545 x 260
Net Weight	12kg / 26.45 lbs
Enclosure Material	0.47" birch plywood
Power Cord	16,4ft / 5mt

* Max.: 2mS burst, RMS power on nominal speaker impedance
Max. peak: based on max peak output voltage and nominal speaker impedance

** Cont. SPL: free space, based on power amp rating and LF transducer average sensitivity data, 125mS time average
Peak SPL: free space, based on max. peak power amp rating and system peak sensitivity, 10mS time average



VENTIS 206A

DIMENSIONAL DRAWINGS

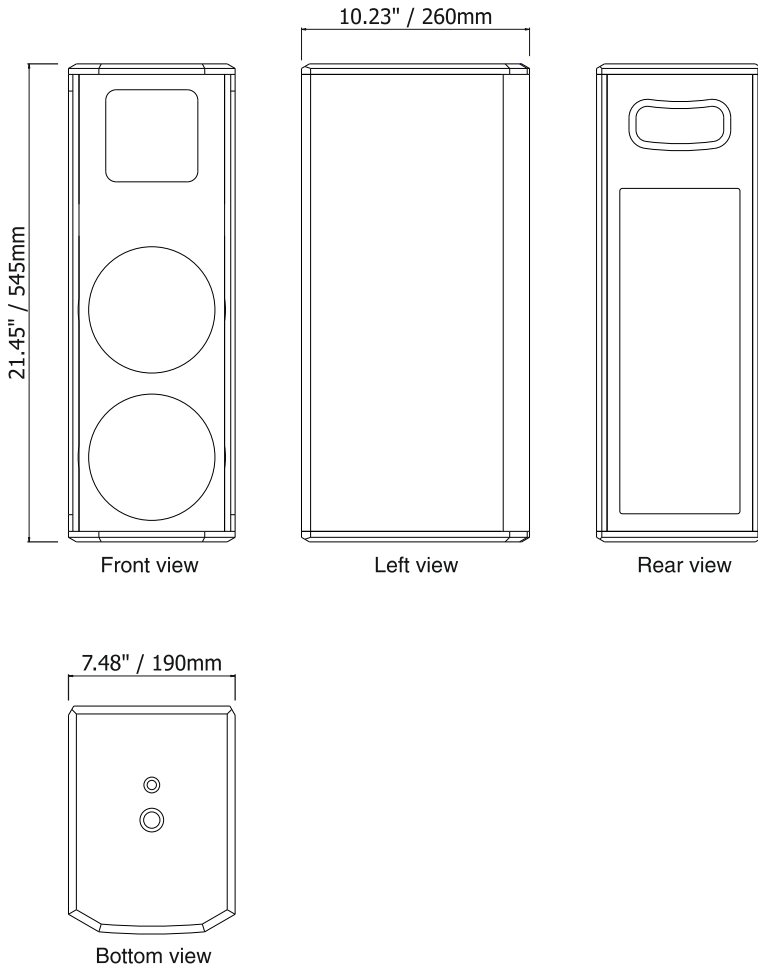

CONTROL PANEL



ACCESSORIES

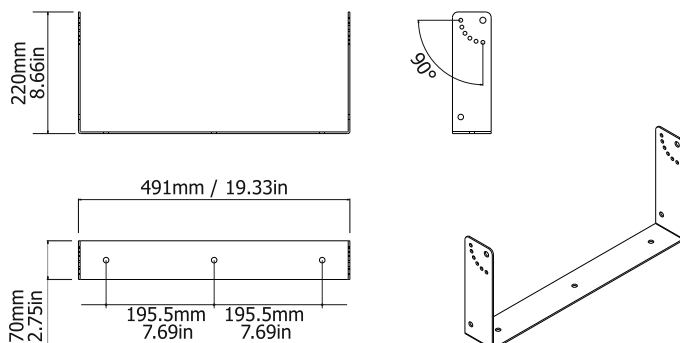

Caution. 

This FBT loudspeaker should be suspended overhead only in accordance with the procedures and limitations specified in the user's manual. This system should be suspended in compliance with local and state overhead suspension ordinances. The VENTIS speakers use only with FBT mount for wall installation.